



# VACUUM PACKING MACHINE SU-520+ 230/50-60/1

Tabletop model. 20m³/h. 420+420 mm.



P/N 1140793

## FEATURES AND BENEFITS

- ✓ Powered by Busch.
- ✓ Vacuum controlled by sensor.
- ✓ Vacuum PLUS.
- ✓ LCD colour screen: all information at a glance.
- ✓ Backlit touch keyboard.
- ✓ Programmable: 25-programme memory. Blocking option.
- ✓ "Pause" button.
- ✓ Phased vacuum programme.
- ✓ Detection of the evaporation of liquids.
- ✓ Double seal.
- ✓ Cordless sealing bar.
- ✓ Progressive decompression.
- ✓ Vac-Norm ready with Automatic decompression.
- ✓ Stainless steel body and chamber. Long-shaped chamber.
- ✓ Damped transparent lid of high durability polycarbonate.
- ✓ Dry-oil programme for drying the pump.
- ✓ Working hours counter for oil changes.
- ✓ Safety system with protection against vacuum failure.

## INCLUDES

- ✓ Filling plate
- ✓ "Plus" sealing system

## ACCESSORIES

- Bag cutting kits
- Filling plates
- Liquid insert plates
- Vac-norm external vacuum kits
- Vac-norm containers
- Smooth bags for vacuum packing
- Trolley for vacuum packing machines
- CG2 Desktop printer for SU vacuum packing machines \*
- Thermal labels for CG2 printer



## SALES DESCRIPTION

Two sealing bars (420+420 mm.)  
 20 m³/h Busch vacuum pump.  
 Vacuum controlled by sensor.



**www.sammic.co.uk**  
 Food Service Equipment Manufacturer  
 Unit 2, Trevanah Road  
 Troon Industrial Park  
 LE4 9LS - Leicester  
 uksales@sammic.com  
 Tel.: +44 0116 246 1900



Project	Date
Item	Qty
Approved	

FOOD PRESERVATION AND SOUS-VIDE  
 VACUUM PACKING MACHINES - "SENSOR ULTRA" LINE

product sheet  
 updated 01/08/2018



# VACUUM PACKING MACHINE SU-520+ 230/50-60/1

Tabletop model. 20m<sup>3</sup>/h. 420+420 mm.



P/N 1140793

## SPECIFICATIONS

Pump capacity: 20 m<sup>3</sup>/h  
 Bar length: 420 mm  
 Total loading: 750 W  
 Vacuum pressure (maximum): 2 mbar  
 Electrical supply: 230 V / 50-60 Hz / 1 ~  
 (5.5 A)

### Internal dimensions

- ✓ Width: 560 mm
- ✓ Depth: 430 mm
- ✓ Height: 183 mm

### External dimensions (WxDxH)

- ✓ Width: 625 mm
- ✓ Depth: 537 mm
- ✓ Height: 513 mm
- Net weight: 80 Kg
- Noise level (1m.): 75 dB(A)
- Background noise: 32 dB(A)

### Crated dimensions

760 x 600 x 670 mm  
 Gross weight: 84 Kg.

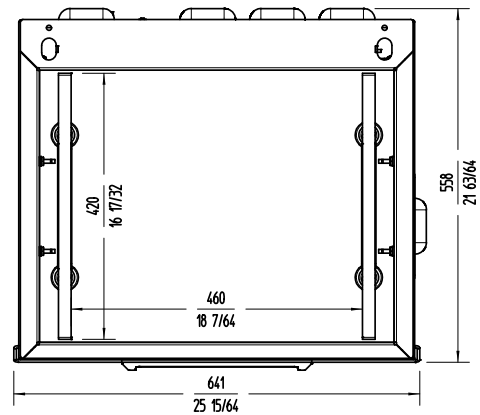
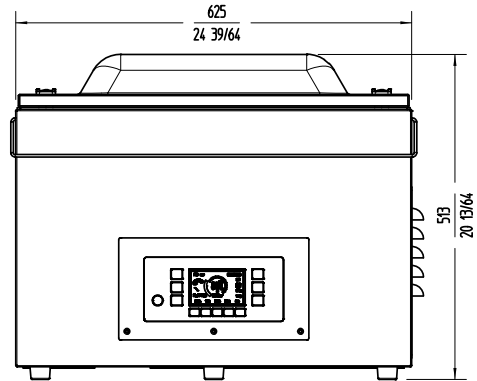
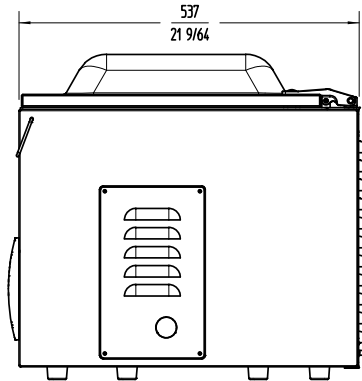

FOOD PRESERVATION AND SOUS-VIDE  
 VACUUM PACKING MACHINES - "SENSOR ULTRA" LINE



**www.sammic.co.uk**  
 Food Service Equipment Manufacturer  
 Unit 2, Trevanth Road  
 Troon Industrial Park  
 LE4 9LS - Leicester  
 uksales@sammic.com  
 Tel.: +44 0116 246 1900



Project	Date
Item	Qty
Approved	